

Mit Motorfahrwerk < 5000 kg (Kurze Bauhöhe) (TMU3)
 With electric travel trolley < 5000 kg (Short headroom) (TMU3)
 Chariot électrique < 5000 kg (Hauteur perdue réduite) (TMU3)

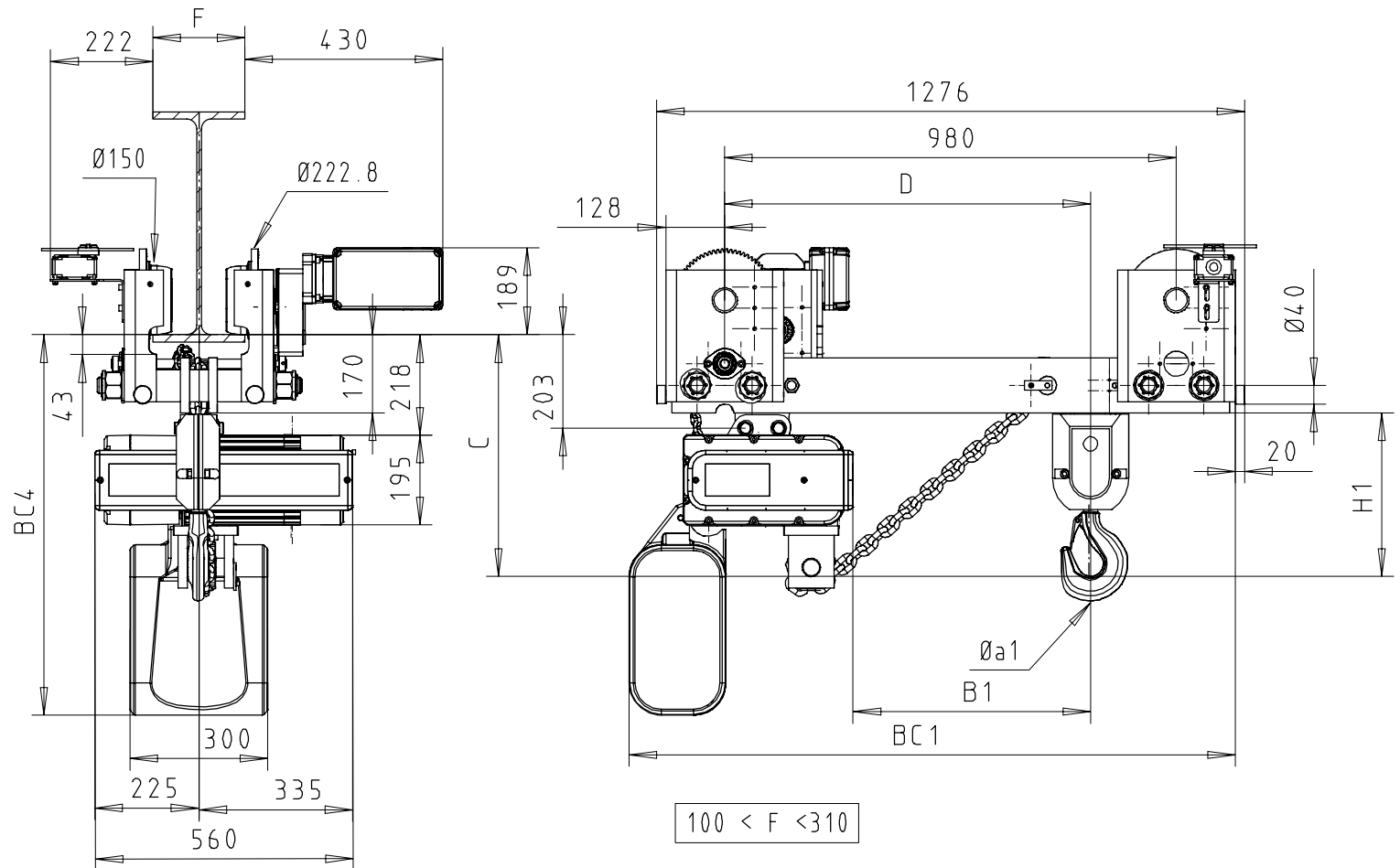

| Chain bag capacity | H1 | | C | | B1 | D | BC4 | | | BC1 | | | Ø a1 | | a2 | | ⊙ kg | |
|--------------------|----|------------|---|------------|-----|-----|-------|-------|-------|-------|-------|-------|------|------------|----|------------|---------|-----|
| | - | SKF SKE | - | SKF SKE | | | type1 | type2 | type3 | type1 | type2 | type3 | - | SKF SKE | - | SKF SKE | | - |
| 1 / 1 | - | 244 | - | 414 | 452 | 746 | 826 | 998 | 1198 | 1316 | 1348 | 1418 | - | 48 | - | 43 | - | 290 |
| 2 / 1 | - | 354 | - | 524 | 501 | 794 | 826 | 998 | 1198 | 1316 | 1348 | 1418 | - | 56 | - | 47 | - | 295 |

| Chain bag capacity | | |
|------------------------------|---------------------------|---------|
| Contenance des bacs à chaîne | | |
| | | SKE-SKF |
| type1 | - | 12m |
| type2 | - | 30m |
| type3 | - | 50m |
| ⊙ kg | m of chain m de chaîne | - |
| | | 2.85 kg |