

CC1

MABLAETTER
DIMENSIONS
ENCOMBREMENTS

SWF
KRANTECHNIK

Mit Motorfahrwerk FNU C3 max 2500Kg (Quer zur Kettenzugachse)
Fixed to electric travel trolley FNU C3 max 2500Kg (perpendicular version)
Accouplé à chariot à direction électrique FNU C3 max 2500Kg (version perpendiculaire)

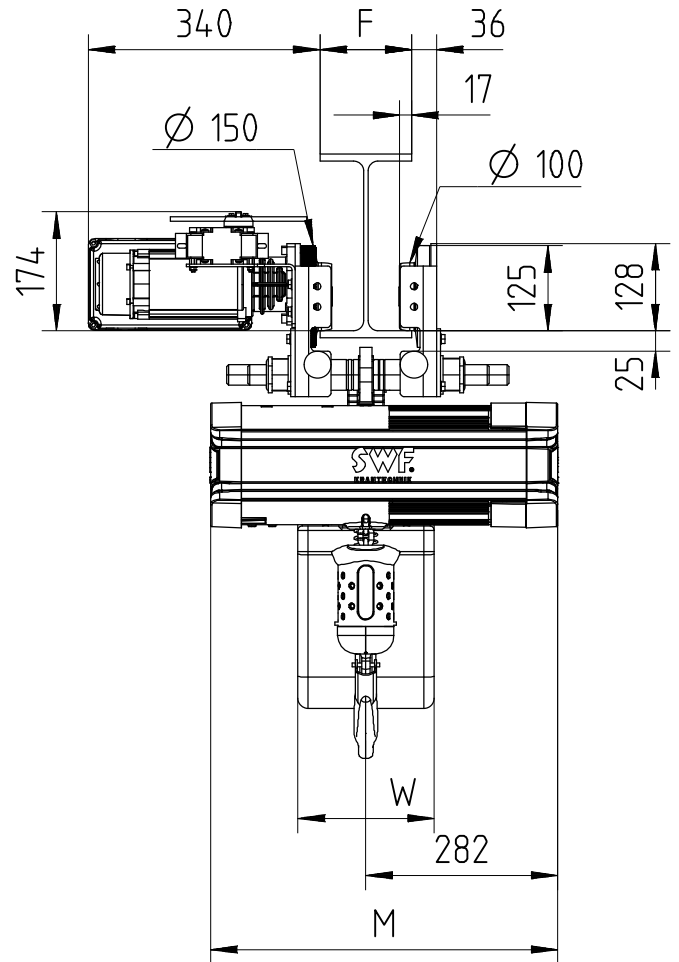
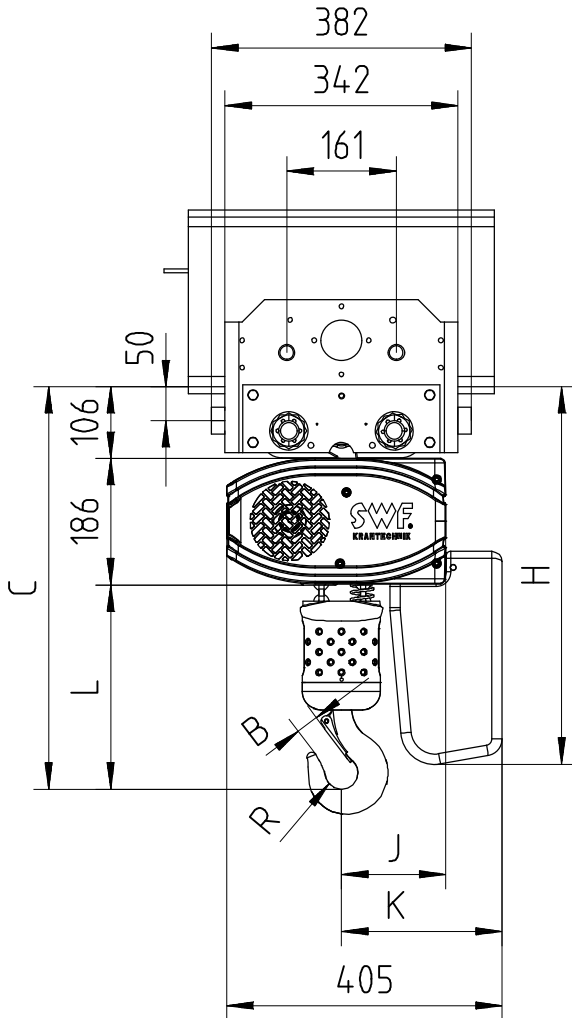

82 < F < 310

Hinweis: Mini. Kurvenradius für Wagen 2500 kg beträgt 2m.
Note: Mini. radius of curve for trolley 2500 Kg is 2m.
Remarque: Mini. rayon de courbe pour chariot 2500 kg est de 2m.

| Chain Size (mm) | Max load (kg) | Falls | Chain bag capacity (m) | Dimensions (mm) | | | | | | | | | | Weight (kg) | | | | |
|-----------------|---------------|-------|------------------------|-----------------|-----|-----|----|-----|-----|-----|-----|-----------|------------|----------------------|---------------------------------------------------|-----|-----|-----|
| | | | | B | C | L | R | J | K | H | W | M | | Weight of chain kg/m | Estimated weight of hoist incl. trolley w/o chain | | | |
| | | | | | | | | | | | | CHAINster | GT/DB/ GLS | | CHAINster | GT | GLS | DB |
| 7X20 | 2500 | 2 | 6 (*) | 33 | 592 | 300 | 24 | 154 | 236 | 555 | 200 | 510 | 641 | 1.1 | 105 | 109 | 107 | 109 |
| | | | 16 (*) | | | | | | | 696 | | | | | | | | |
| | | | 30 (*) | | | | | | | 766 | | | | | | | | |

GLS: Getriebeendechalter / Gear Limit Switch / Fin De Course à Cames
DB: Zusätzliche Bremse / Double Brake / Double Freins

(*) In case of 2-fall hoist, available lifting height is half of the chain bag maximum capacity

SWF behält sich das Recht auf Veränderung oder Richtigstellung der oben genannten Information ohne weitere Mitteilung vor.
SWF reserves the right to alter or amend the above information without notice.

SWF se réserve le droit de modifier sans préavis les caractéristiques de son matériel.

DISCLOSED WITHOUT PRIOR WRITTEN CONSENT OF THE COMPANY. ANY COPIES OF THIS DOCUMENT MADE BY ANY METHOD MUST ALSO INCLUDE A COPY OF THIS LEGEND.

53564235
53564235-DRW1
15/04/2016